

OUTLINE DRAWING

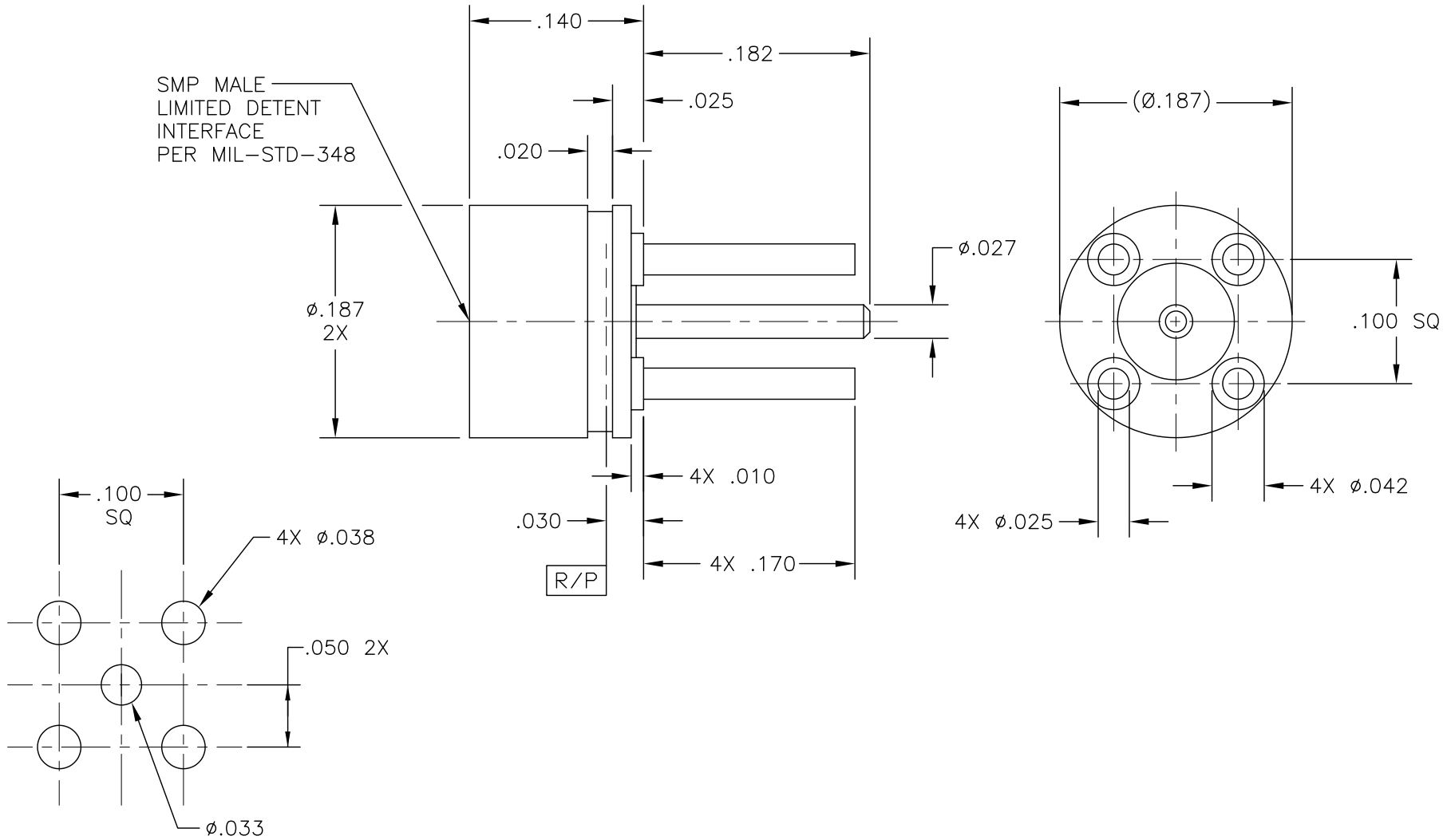



MOUNTING HOLE PATTERN

COMPONENT	MATERIAL & FINISH	MICRO-MODE PRODUCTS, INC. <i>The Reliable Connection to the Future</i>	El Cajon, CA 92020 ph 619.449.3844 www.micromode.com	CAGE CODE 15907	
BODY & CONTACT	BeCu, ASTM B196, UNS C17300 <small>GOLD PLATE, MIL-DTL-45204, TYPE 1, GRADE C, CLASS 1 OVER NICKEL PLATE, MIL-C-26074</small>	ASSY PROCEDURES: N/A	SMP MALE, LIMITED DETENT PCB MOUNT, PRE-TINNED		
INSULATOR	PEEK 1000, ASTM D6262	INSERTION/EXTRACTION TOOL: N/A			
SOLDER	Sn60 OR Sn63		PART NO.	REVISION	
		SHEET 1 OF 2	3-13-15 . MP	MMSP-14096	A

OUTLINE DRAWING

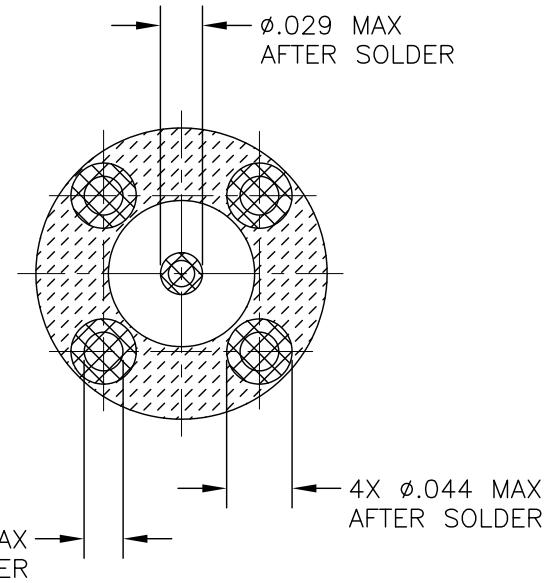
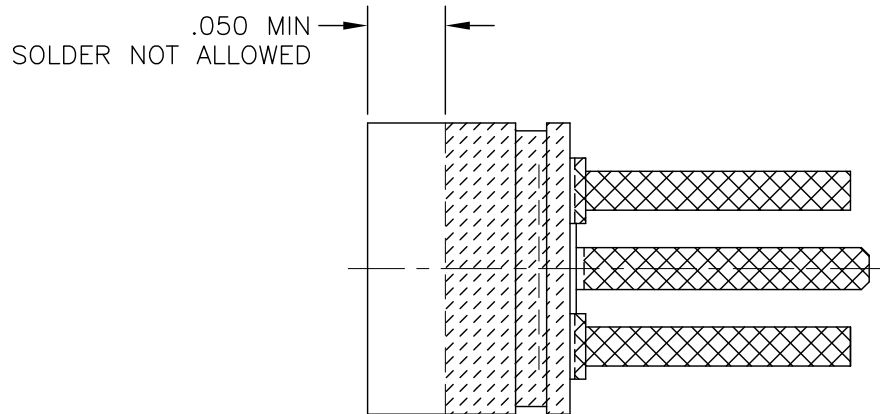
OUTLINE DRAWING



 SOLDER REQUIRED
(Sn63 SOLDER)

 SOLDER OPTIONAL



MICRO-MODE PRODUCTS, INC.
The Reliable Connection to the Future

El Cajon, CA 92020
ph 619.449.3844
www.micromode.com

CAGE CODE
15907

ASSY PROCEDURES: N/A

INSERTION/EXTRACTION TOOL: N/A

SMP MALE, LIMITED DETENT
PCB MOUNT, PRE-TINNED

PART NO.

MMSP-14096

REVISION

A

SHEET 2 OF 2

3-13-15 . MP

OUTLINE DRAWING