

MSSS MALE FULL DETENT TRUNCATED (.055 LG) INTERFACE

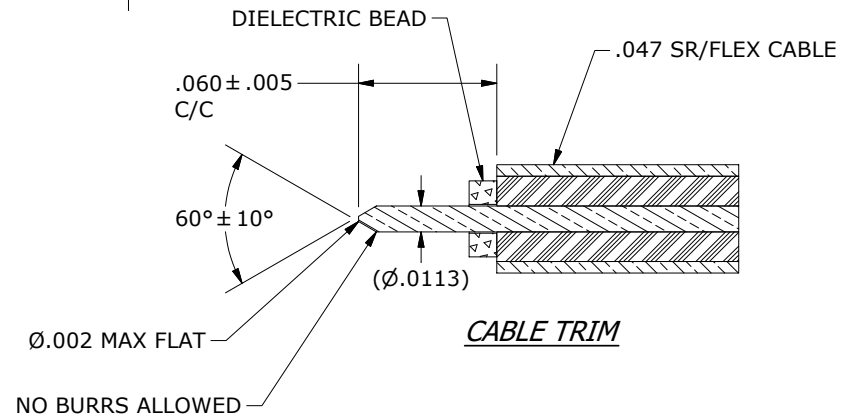
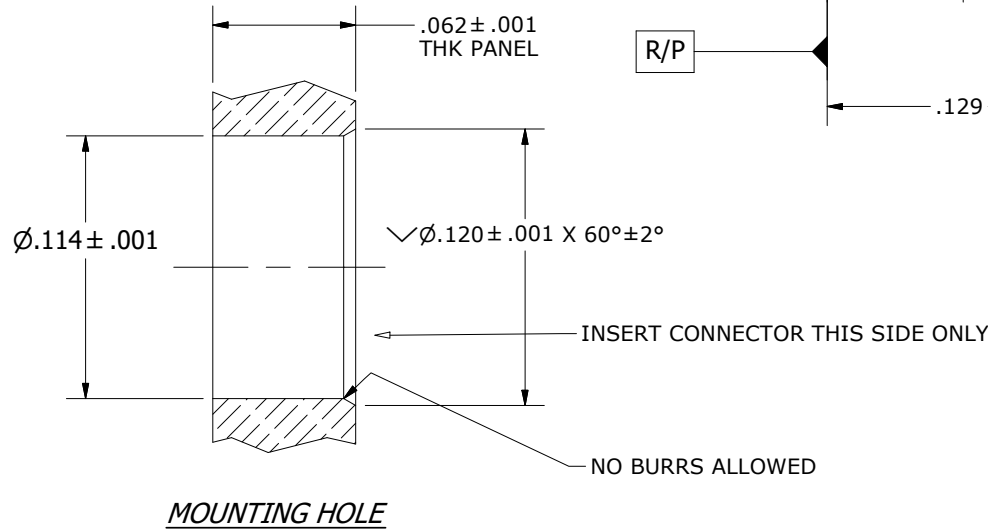
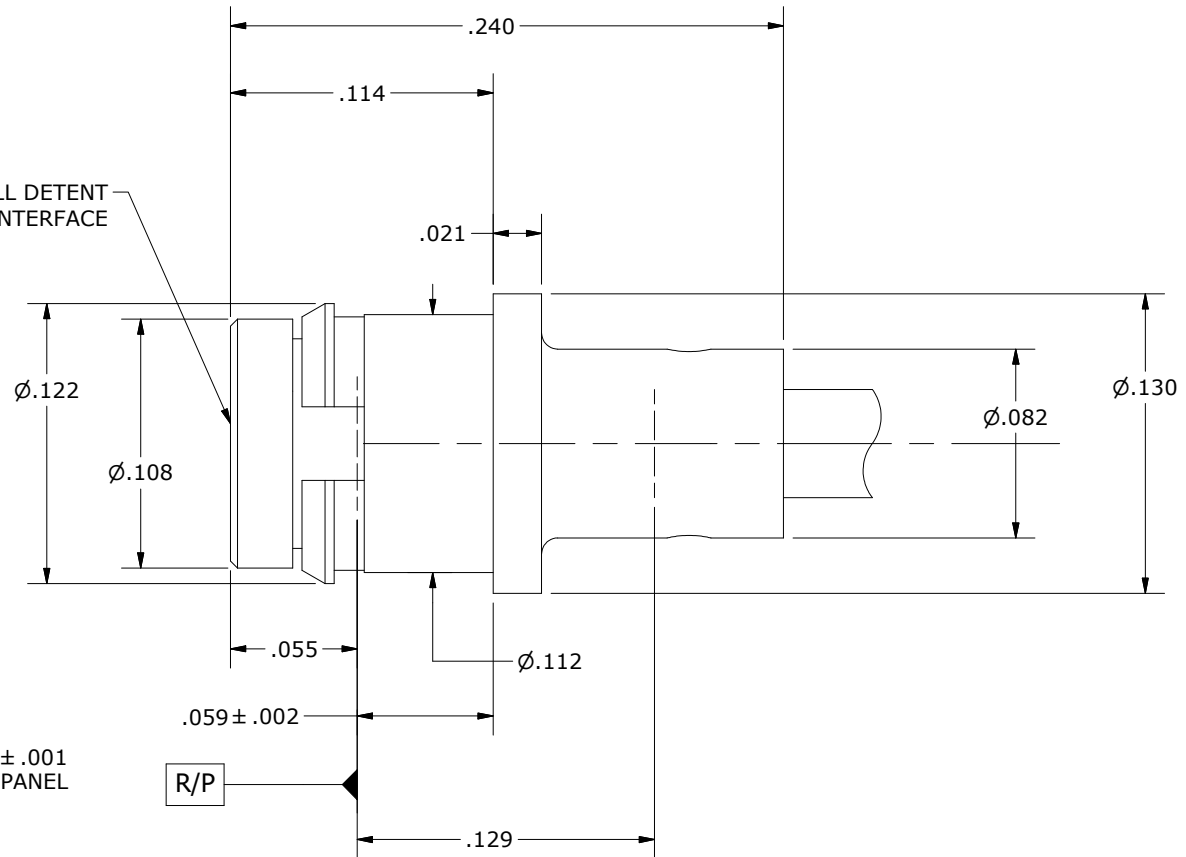
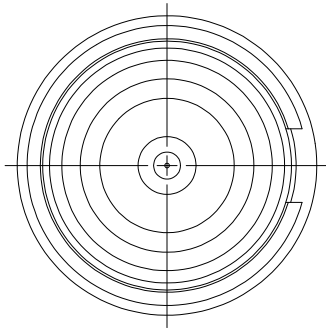

COMPONENT	MATERIAL	FINISH	MICRO-MODE PRODUCTS, INC. <i>The Reliable Connection to the Future</i>		El Cajon, CA 92020 ph 619.449.3844 www.micromode.com	CAGE CODE 15907
BODY, CONTACT	BeCu, ASTM B196, UNS C17300	GOLD PLATE, MIL-DTL-45204, TYPE 1, GRADE C, CLASS 1	ASSEMBLY PROCEDURES: TBD		MSSS FULL DETENT SNAP-IN TO .047 SR/FLEX CABLE	
INSULATOR	PTFE PER ASTM D1710 TYPE 1, GRADE 1, CLASS A		TOOL: MMTL-7509		PART NO. MSSS-16316	
DIELECTRIC BEAD	ULTEM 1000, ASTM D5205		SHEET 1 OF 1 10/26/2017 EB MT		REVISION A	
SNAP RING	BeCu, ASTM B196, UNS C17300	ELECTROLESS NICKEL PLATE, AMS-C-26074, TYPE 1, 50 MICROINCHES MINIMUM				