

COMPONENT	MATERIAL AND FINISH	
BODY	303 CRES, ASTM A582	PASSIVATE, AMS-QQ-P-35
LOCKRING	BeCu, ASTM B196, UNS C17300	
COUPLING NUT	303 CRES, ASTM A582	PASSIVATE, AMS-QQ-P-35
GASKET	SILICONE RUBBER	

PART NO. MSSM-5550

OUTLINE DRAWING

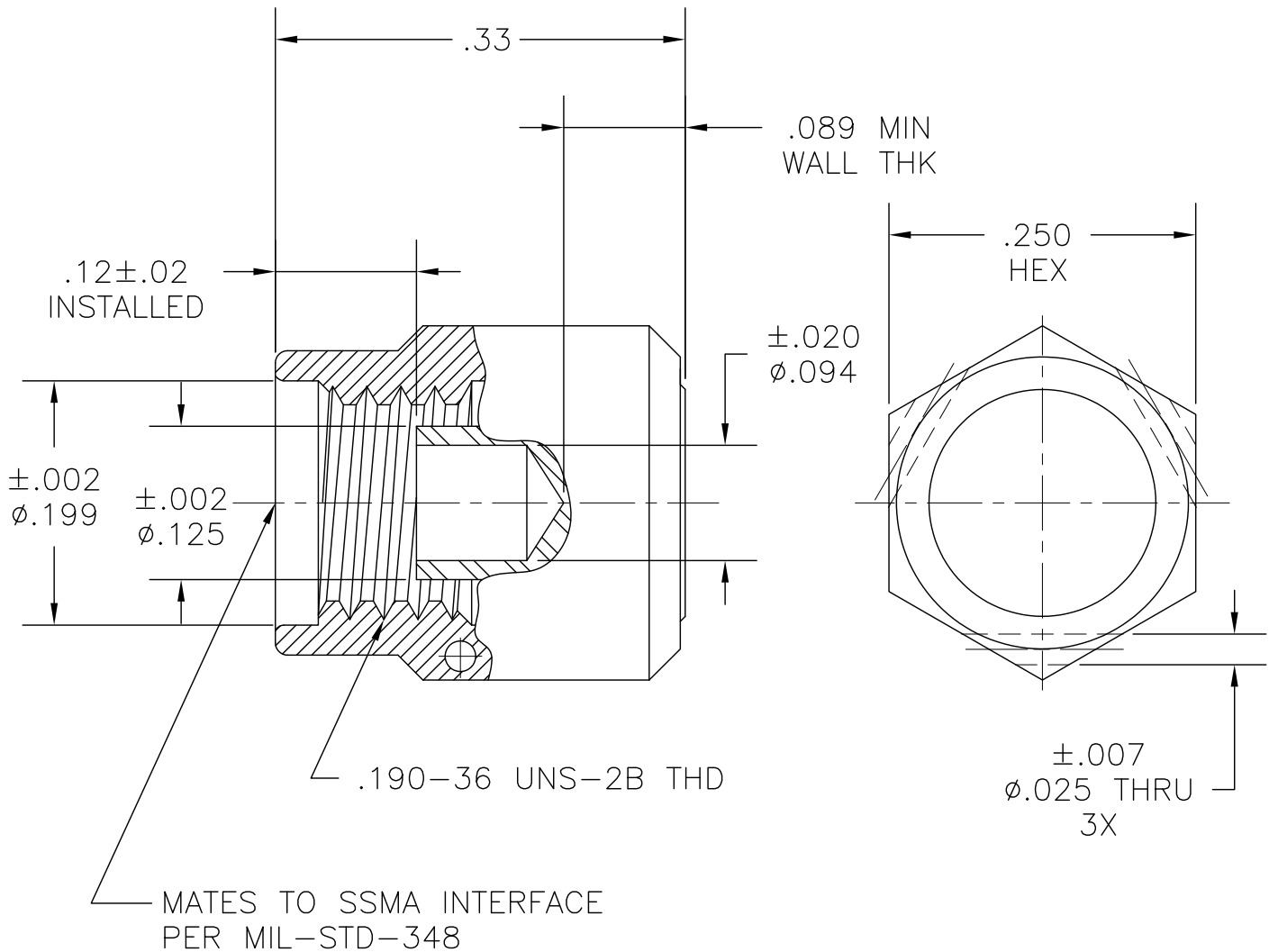

MICRO-MODE PRODUCTS, INC.  
*The Reliable Connection to the Future*

El Cajon, CA 92020  
ph 619.449.3844  
www.micromode.com

CAGE CODE  
15907

ASSY PROCEDURES: N/A

INSERTION/EXTRACTION TOOL: N/A

MSSM, DUST CAP, NON-SHORTING

PART NO.

MSSM-5550

REVISION

C

SHEET 1 OF 1 | OL5550 9-25-02 RF EB