

OUTLINE DRAWING

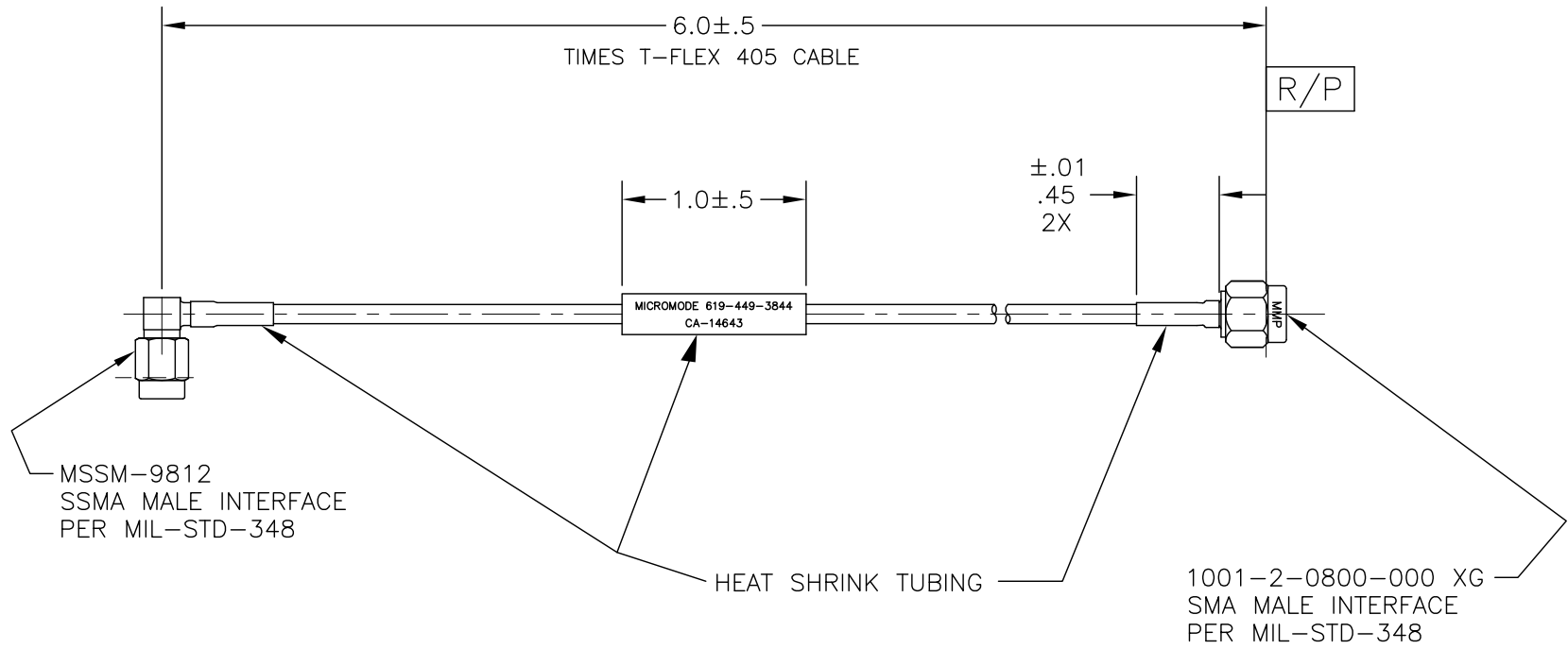

COMPONENT	MATERIAL & FINISH	
SSMA BODY, CONTACTS,	BeCu, ASTM B196, UNS C17300	GOLD PLATE, MIL-G-45204, TYPE 1, GRADE C, CLASS 1
INSULATORS	PTFE, ASTM D1710, TYPE I, GRADE 1, CL A	
SMA BODY	303 CRES, ASTM A582	GOLD PLATE, MIL-G-45204, TYPE 1, GRADE C, CLASS 1
SMA, COUPLING NUT	303 CRES, ASTM A582	PASSIVATE, AMS-QQ-P-35
SSMA COUPLING NUT	303 CRES, ASTM A582	GOLD PLATE, MIL-G-45204, TYPE 1, GRADE C, CLASS 1
HEAT SHRINK TUBING	POLYOLEFIN AMS-DTL-23053/5 CL 1, BLK OR WH	
LOCKRING	BeCu, ASTM B196, UNS C17300	OR BeCu, ASTM B197 UNS C17200
GASKET	SILICONE RUBBER, ZZ-R-765C	



MICRO-MODE PRODUCTS, INC.
The Reliable Connection to the Future

El Cajon, CA 92020
ph 619.449.3844
www.micromode.com

CAGE CODE
15907

ASSY PROCEDURES: N/A

INSERTION/EXTRACTION TOOL: N/A

SSMA MALE TO SMA MALE
T-FLEX 405, 6.0 IN

PART NO.

CA-14643

REVISION

—

SHEET 1 OF 1

11-16-15 SE MT

OUTLINE DRAWING