

COMPONENT	MATERIAL AND FINISH	
BODY	303 CRES, ASTM A582	PASSIVATE, AMS-QQ-P-35
INSULATORS	PTFE, ASTM D1710	TYPE I, GRADE 1, CLASS A
CONTACT	BeCu, ASTM B196, UNS C17300	GOLD PLATE, MIL-G-45204, TYPE 1, GRADE C, CLASS 1
JAM NUT	303 CRES, ASTM A582 PASSIVATE, AMS-QQ-P-35	GOLD PLATE, MIL-G-45204, TYPE 1, GRADE C, CLASS 1
LOCKWASHER	PHOSPHOR BRONZE QQ-B-750	GOLD PLATE, MIL-G-45204, TYPE 1, GRADE C, CLASS 1
O-RING	SILICONE, ASTM D1418	

PART NO. MSMA-5434

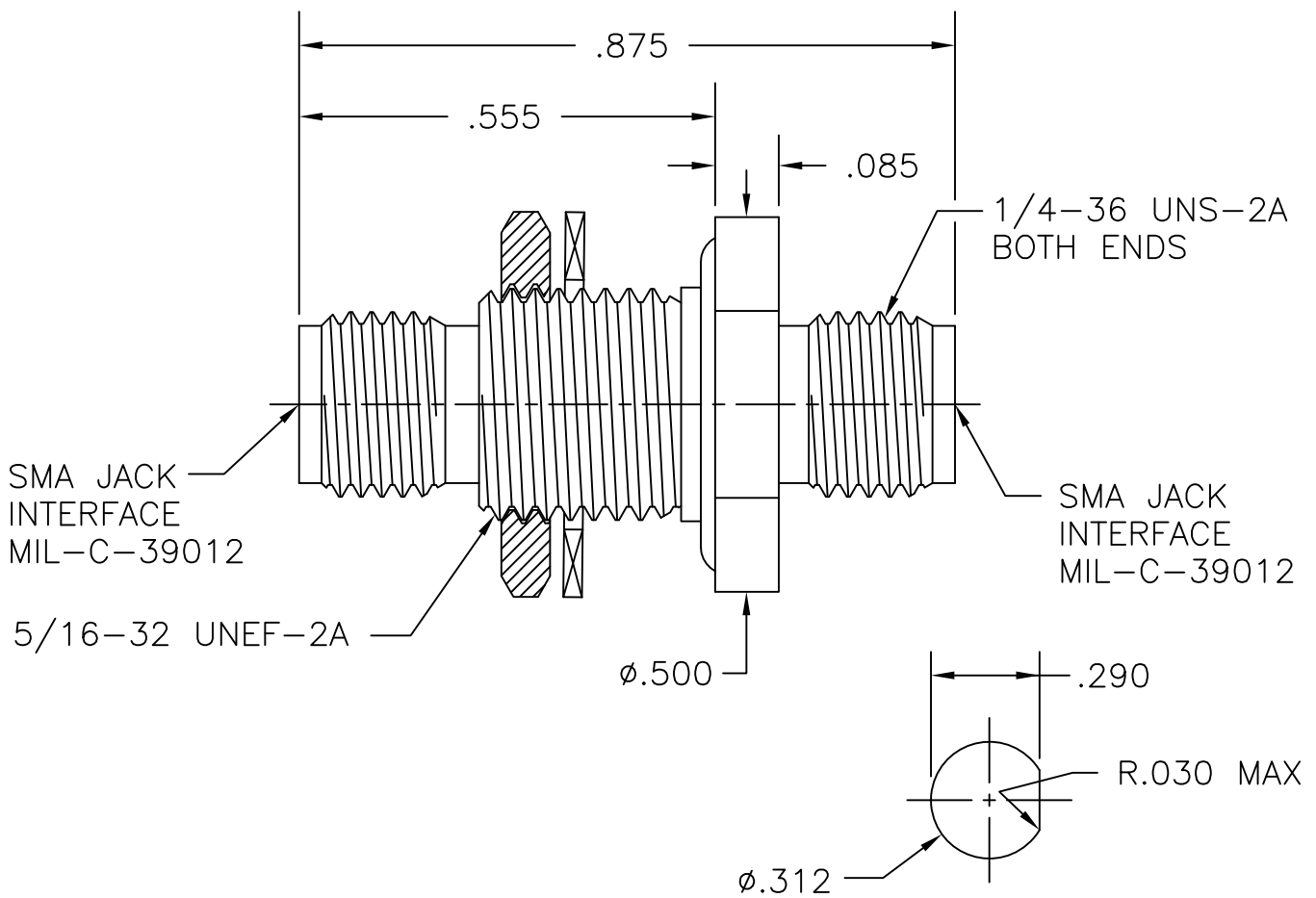

OUTLINE DRAWING

PANEL MTG HOLE

SCALE 2:1



MICRO-MODE PRODUCTS, INC.
The Reliable Connection to the Future

El Cajon, CA 92020
ph 619.449.3844
www.micromode.com

CAGE CODE
15907

ASSY PROCEDURES: N/A

INSERTION/EXTRACTION TOOL: N/A

SMA JACK TO SMA JACK, BLKD FEEDTHRU
HERMETIC, BARBED CAPTIVE

PART NO.

MSMA-5434

REVISION

02

SHEET 1 OF 1 | OL5434 7-22-02 RF MP