

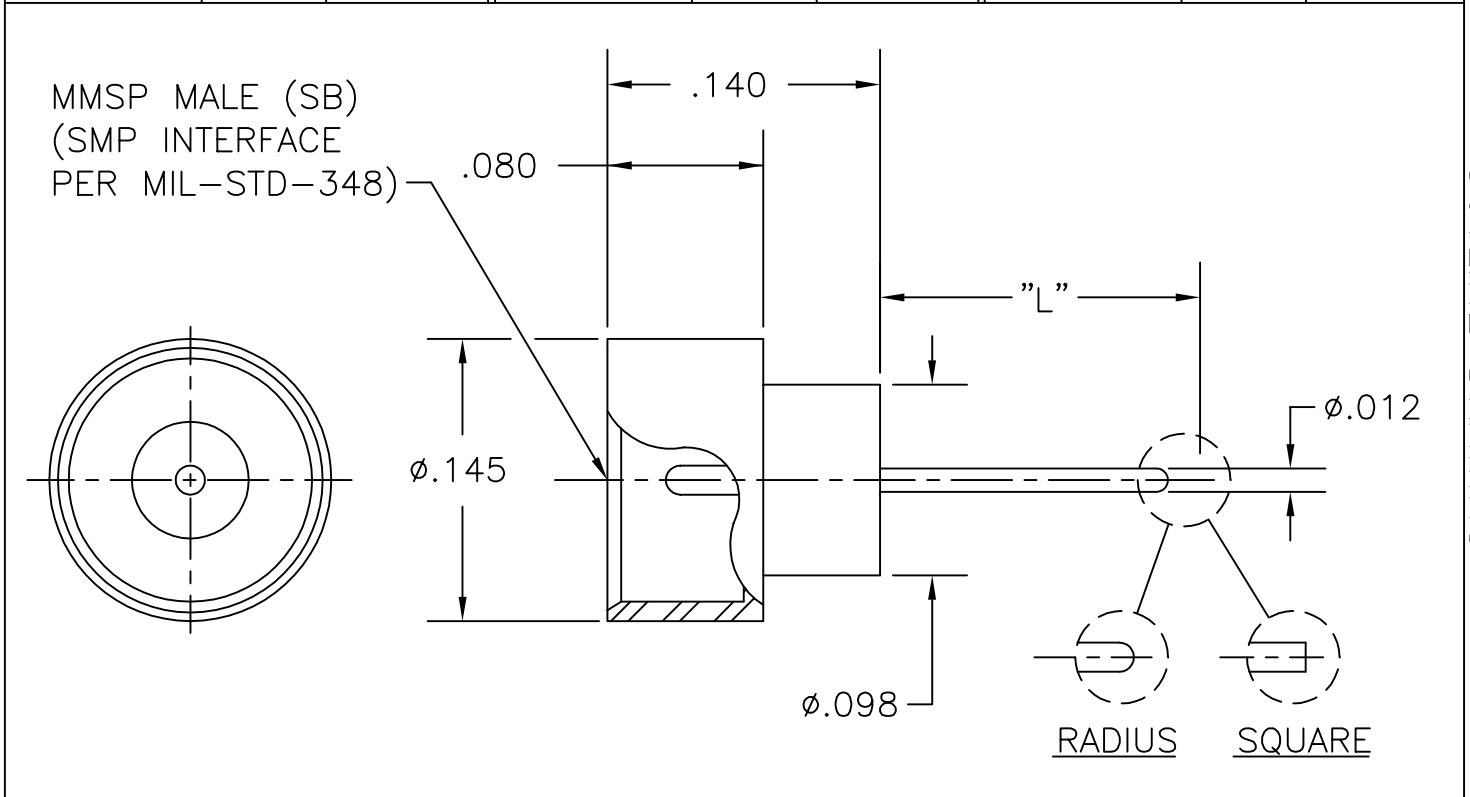

COMPONENT	MATERIAL AND FINISH	
BODY & PIN	KOVAR PER MIL-I-23011 ASTM F-15	GOLD PLATE, MIL-G-45204, TYPE 1, GRADE C, CLASS 1
GLASS	CORNING #7070 OR EQUIVALENT	

PART NUMBER	LENGTH "L"	PIN END	PART NUMBER	LENGTH "L"	PIN END	PART NUMBER	LENGTH "L"	PIN END
MMSP-4332	.025	RADIUS	MMSP-4350	.070	RADIUS	MMSP-4368	.115	RADIUS
MMSP-4333	.025	SQUARE	MMSP-4351	.070	SQUARE	MMSP-4369	.115	SQUARE
MMSP-4334	.030	RADIUS	MMSP-4352	.075	RADIUS	MMSP-4370	.120	RADIUS
MMSP-4335	.030	SQUARE	MMSP-4353	.075	SQUARE	MMSP-4371	.120	SQUARE
MMSP-4336	.035	RADIUS	MMSP-4354	.080	RADIUS	MMSP-4372	.125	RADIUS
MMSP-4337	.035	SQUARE	MMSP-4355	.080	SQUARE	MMSP-4373	.125	SQUARE
MMSP-4338	.040	RADIUS	MMSP-4356	.085	RADIUS	MMSP-4374	.130	RADIUS
MMSP-4339	.040	SQUARE	MMSP-4357	.085	SQUARE	MMSP-4375	.130	SQUARE
MMSP-4340	.045	RADIUS	MMSP-4358	.090	RADIUS	MMSP-4376	.135	RADIUS
MMSP-4341	.045	SQUARE	MMSP-4359	.090	SQUARE	MMSP-4377	.135	SQUARE
MMSP-4342	.050	RADIUS	MMSP-4360	.095	RADIUS	MMSP-4378	.140	RADIUS
MMSP-4343	.050	SQUARE	MMSP-4361	.095	SQUARE	MMSP-4379	.140	SQUARE
MMSP-4344	.055	RADIUS	MMSP-4362	.100	RADIUS	MMSP-4380	.145	RADIUS
MMSP-4345	.055	SQUARE	MMSP-4363	.100	SQUARE	MMSP-4381	.145	SQUARE
MMSP-4346	.060	RADIUS	MMSP-4364	.105	RADIUS	MMSP-4382	.150	RADIUS
MMSP-4347	.060	SQUARE	MMSP-4365	.105	SQUARE	MMSP-4383	.150	SQUARE
MMSP-4348	.065	RADIUS	MMSP-4366	.110	RADIUS			
MMSP-4349	.065	SQUARE	MMSP-4367	.110	SQUARE			

PART NO. MMSP-4332 → MMSP-4383



OUTLINE DRAWING

 MICRO-MODE PRODUCTS, INC. <i>The Reliable Connection to the Future</i>	El Cajon, CA 92020 ph 619.449.3844 www.micromode.com	CAGE CODE 15907
	ASSY PROCEDURE: MMAP-2695 LOCATOR TOOL: MMTL-2698	
MMSP, MALE, SMOOTH BORE HERMETIC SHROUD TO $\phi .012$ C/C		PART NO. MMSP-4332 → MMSP-4383 REVISION A
SHEET 1 OF 1 OL4332 5-11-01 RF EB		