

COMPONENT	MATERIAL AND FINISH	
BODY & PIN	KOVAR PER MIL-I-23011 ASTM F-15	GOLD PLATE, MIL-G-45204, TYPE 1, GRADE C, CLASS 1
GLASS	CORNING #7070 OR EQUIVALENT	

PART NUMBER	LENGTH "L"	PIN END	PART NUMBER	LENGTH "L"	PIN END	PART NUMBER	LENGTH "L"	PIN END
MMSP-2857	.025	RADIUS	MMSP-2875	.070	RADIUS	MMSP-2893	.115	RADIUS
MMSP-2858	.025	SQUARE	MMSP-2876	.070	SQUARE	MMSP-2894	.115	SQUARE
MMSP-2859	.030	RADIUS	MMSP-2877	.075	RADIUS	MMSP-2895	.120	RADIUS
MMSP-2860	.030	SQUARE	MMSP-2878	.075	SQUARE	MMSP-2896	.120	SQUARE
MMSP-2861	.035	RADIUS	MMSP-2879	.080	RADIUS	MMSP-2897	.125	RADIUS
MMSP-2862	.035	SQUARE	MMSP-2880	.080	SQUARE	MMSP-2898	.125	SQUARE
MMSP-2863	.040	RADIUS	MMSP-2881	.085	RADIUS	MMSP-2899	.130	RADIUS
MMSP-2864	.040	SQUARE	MMSP-2882	.085	SQUARE	MMSP-2900	.130	SQUARE
MMSP-2865	.045	RADIUS	MMSP-2883	.090	RADIUS	MMSP-2901	.135	RADIUS
MMSP-2866	.045	SQUARE	MMSP-2884	.090	SQUARE	MMSP-2902	.135	SQUARE
MMSP-2867	.050	RADIUS	MMSP-2885	.095	RADIUS	MMSP-2903	.140	RADIUS
MMSP-2868	.050	SQUARE	MMSP-2886	.095	SQUARE	MMSP-2904	.140	SQUARE
MMSP-2869	.055	RADIUS	MMSP-2887	.100	RADIUS	MMSP-2905	.145	RADIUS
MMSP-2870	.055	SQUARE	MMSP-2888	.100	SQUARE	MMSP-2906	.145	SQUARE
MMSP-2871	.060	RADIUS	MMSP-2889	.105	RADIUS	MMSP-2907	.150	RADIUS
MMSP-2872	.060	SQUARE	MMSP-2890	.105	SQUARE	MMSP-2908	.150	SQUARE
MMSP-2873	.065	RADIUS	MMSP-2891	.110	RADIUS			
MMSP-2874	.065	SQUARE	MMSP-2892	.110	SQUARE			

PART NO. MMSP-2857 → MMSP-2908

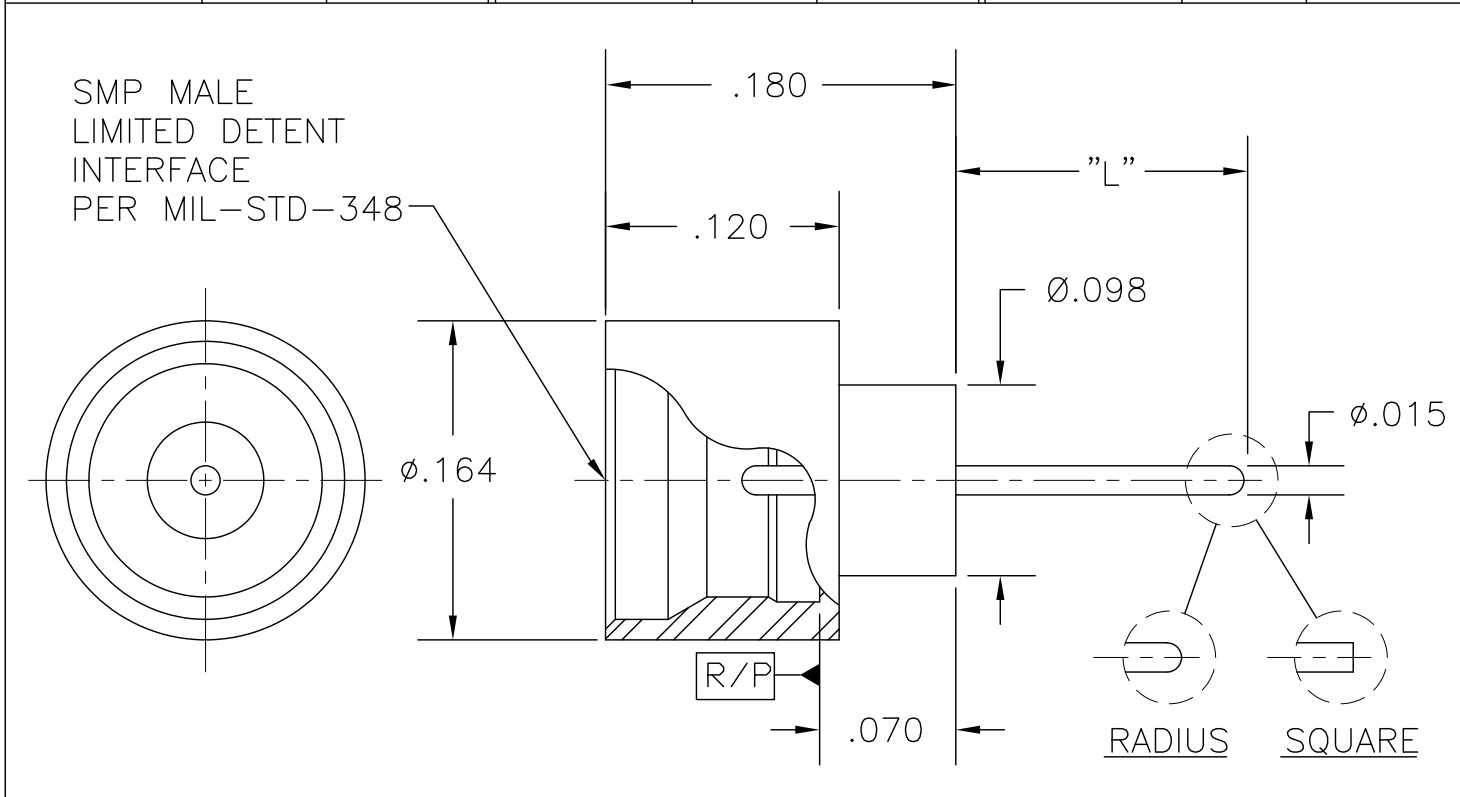

OUTLINE DRAWING



MICRO-MODE PRODUCTS, INC.
The Reliable Connection to the Future

El Cajon, CA 92020
ph 619.449.3844
www.micromode.com

CAGE CODE
15907

ASSY PROCEDURE: MMAP-2695	MMSP, MALE, LIMITED DETENT HERMETIC SHROUD	PART NO. MMSP-2857 → MMSP-2908	REVISION D
LOCATOR TOOL: MMTL-2697			
SHEET 1 OF 1	OL2857 4-27-98	MM EB	