

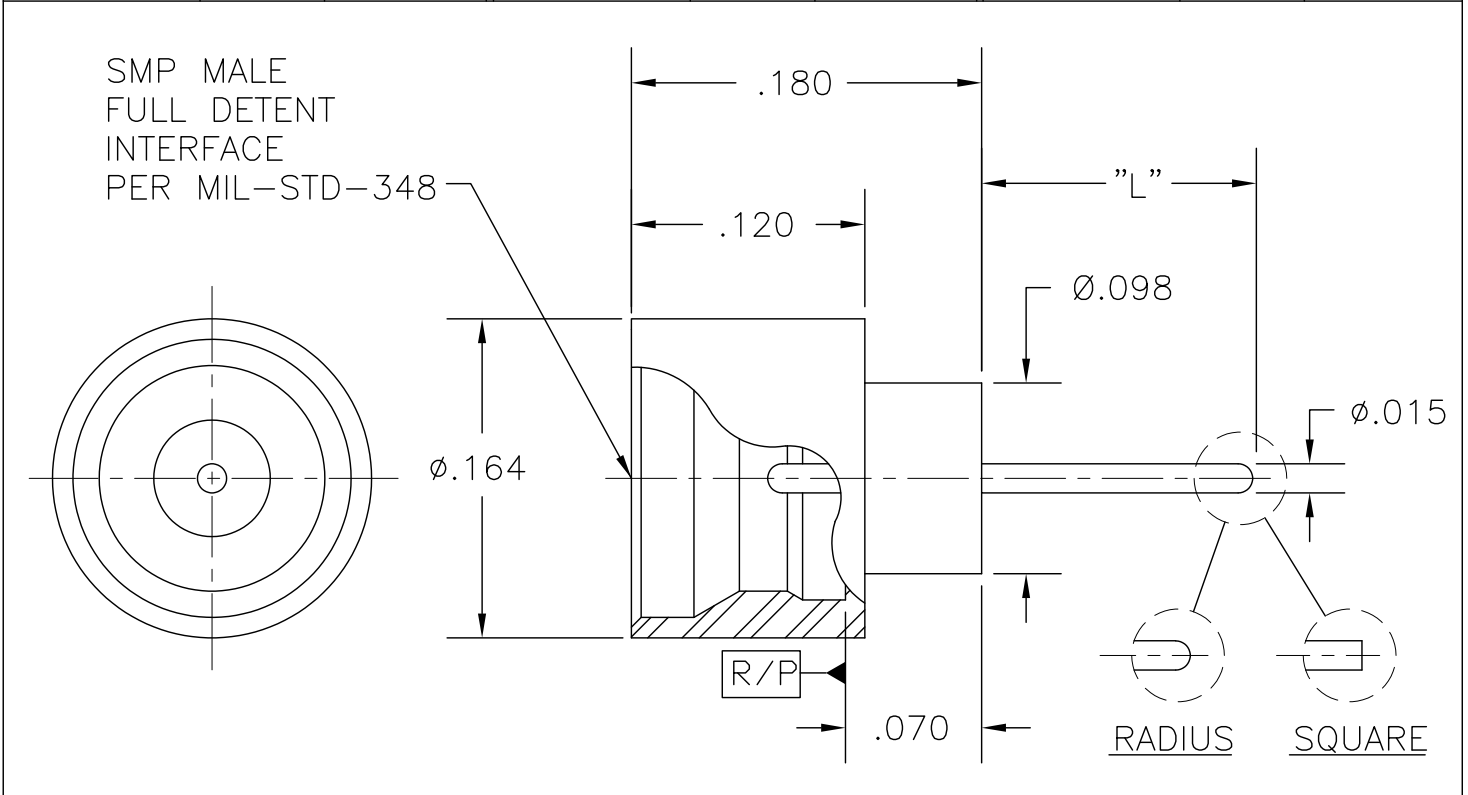

COMPONENT	MATERIAL AND FINISH	
BODY & PIN	KOVAR PER MIL-I-23011 ASTM F-15	GOLD PLATE, MIL-G-45204, TYPE 1, GRADE C, CLASS 1
GLASS	CORNING #7070 OR EQUIVALENT	

PART NUMBER	LENGTH "L"	PIN END	PART NUMBER	LENGTH "L"	PIN END	PART NUMBER	LENGTH "L"	PIN END
MMSP-2753	.025	RADIUS	MMSP-2771	.070	RADIUS	MMSP-2789	.115	RADIUS
MMSP-2754	.025	SQUARE	MMSP-2772	.070	SQUARE	MMSP-2790	.115	SQUARE
MMSP-2755	.030	RADIUS	MMSP-2773	.075	RADIUS	MMSP-2791	.120	RADIUS
MMSP-2756	.030	SQUARE	MMSP-2774	.075	SQUARE	MMSP-2792	.120	SQUARE
MMSP-2757	.035	RADIUS	MMSP-2775	.080	RADIUS	MMSP-2793	.125	RADIUS
MMSP-2758	.035	SQUARE	MMSP-2776	.080	SQUARE	MMSP-2794	.125	SQUARE
MMSP-2759	.040	RADIUS	MMSP-2777	.085	RADIUS	MMSP-2795	.130	RADIUS
MMSP-2760	.040	SQUARE	MMSP-2778	.085	SQUARE	MMSP-2796	.130	SQUARE
MMSP-2761	.045	RADIUS	MMSP-2779	.090	RADIUS	MMSP-2797	.135	RADIUS
MMSP-2762	.045	SQUARE	MMSP-2780	.090	SQUARE	MMSP-2798	.135	SQUARE
MMSP-2763	.050	RADIUS	MMSP-2781	.095	RADIUS	MMSP-2799	.140	RADIUS
MMSP-2764	.050	SQUARE	MMSP-2782	.095	SQUARE	MMSP-2800	.140	SQUARE
MMSP-2765	.055	RADIUS	MMSP-2783	.100	RADIUS	MMSP-2801	.145	RADIUS
MMSP-2766	.055	SQUARE	MMSP-2784	.100	SQUARE	MMSP-2802	.145	SQUARE
MMSP-2767	.060	RADIUS	MMSP-2785	.105	RADIUS	MMSP-2803	.150	RADIUS
MMSP-2768	.060	SQUARE	MMSP-2786	.105	SQUARE	MMSP-2804	.150	SQUARE
MMSP-2769	.065	RADIUS	MMSP-2787	.110	RADIUS			
MMSP-2770	.065	SQUARE	MMSP-2788	.110	SQUARE			

PART NO. MMSP-2753 → MMSP-2804



OUTLINE DRAWING

 MICRO-MODE PRODUCTS, INC. <i>The Reliable Connection to the Future</i>	El Cajon, CA 92020 ph 619.449.3844 www.micromode.com	CAGE CODE 15907
	ASSY PROCEDURE: MMAP-2695 LOCATOR TOOL: MMTL-2696	
MMSP, MALE, FULL DETENT HERMETIC SHROUD		PART NO. MMSP-2753 → MMSP-2804
SHEET 1 OF 1 OL2753 4-27-98 MM EB		REVISION D