

COMPONENT	MATERIAL AND FINISH	
BODY, CONTACT, & BUSHING	BeCu, ASTM B196, UNS C17300	GOLD PLATE, MIL-G-45204, TYPE 1, GRADE C, CLASS 1
INSULATORS	PTFE, ASTM D1710, TYPE I, GRADE 1, CLASS A	
MMSP FD BODY	303 CRES, ASTM A582	PASSIVATE, AMS-QQ-P-35
INSULATOR	ULTEM, ASTM D5205	
SPRINGS	MUSIC WIRE	

PART NO. MMSP-6405

OUTLINE DRAWING

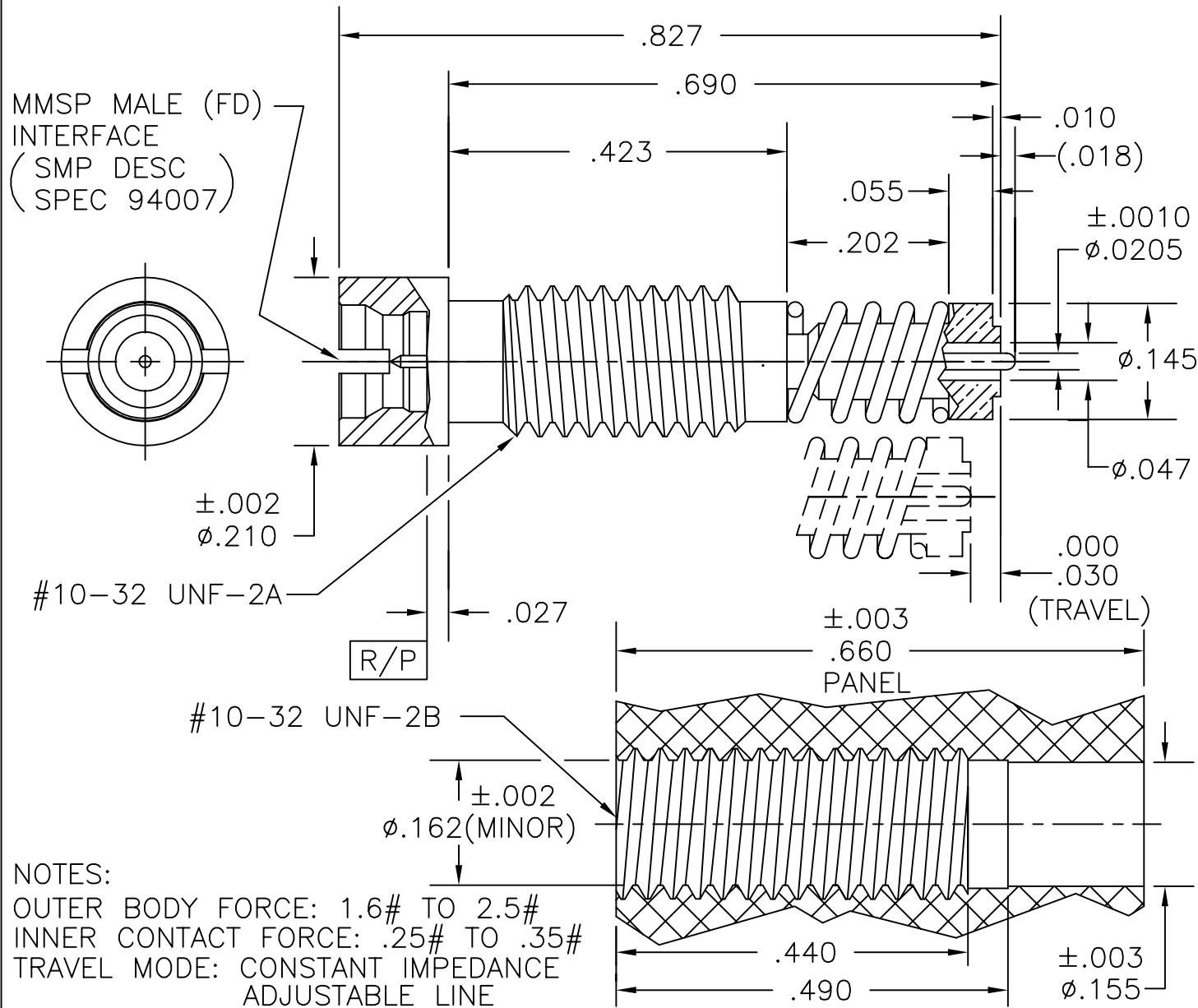

MICRO-MODE PRODUCTS, INC.  
*The Reliable Connection to the Future*

El Cajon, CA 92020 Peoria, AZ 85345  
 (619) 449-3844 (602) 334-8944

CAGE CODE  
 15907

ASSY PROCEDURES: N/A

INSERTION/EXTRACTION TOOL: N/A

MMSP (M) FULL DETENT,  
 THREAD-IN POGO CONNECTOR

PART NO.

MMSP-6405

REVISION

—

SHEET 1 OF 1

OL6405 5-20-99

PC