

COMPONENT	MATERIAL AND FINISH	
BODY & PIN	KOVAR, MIL-I-23011, CLASS 1	GOLD PLATE, MIL-G-45204, TYPE I, GRADE C, CLASS 1
GLASS	CORNING #7070 OR EQUIVALENT	

PART NO. MSSS-5982

OUTLINE DRAWING

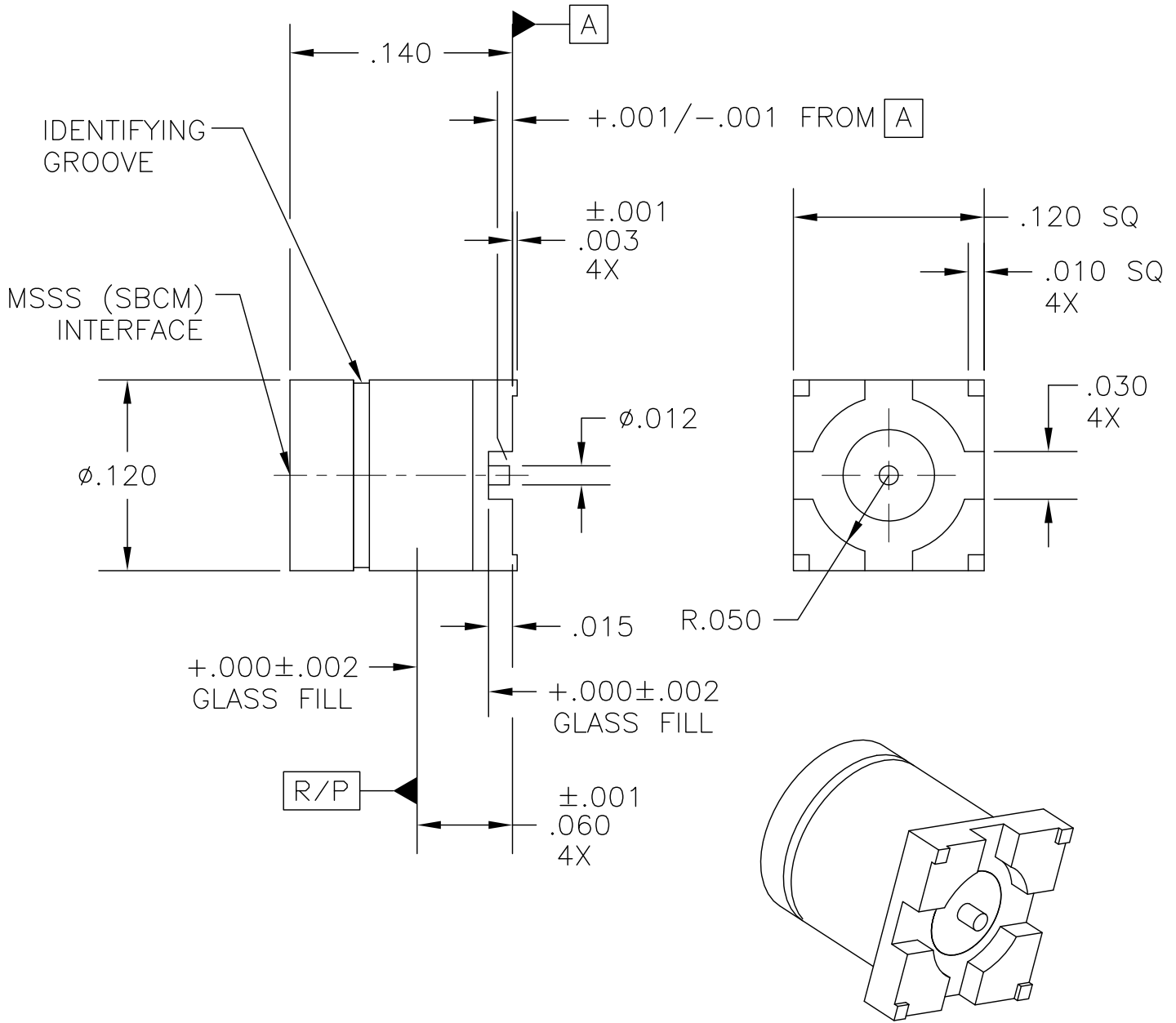

MICRO-MODE PRODUCTS, INC.
The Reliable Connection to the Future

El Cajon, CA 92020
ph 619.449.3844
www.micromode.com

CAGE CODE
15907

ASSY PROCEDURES: N/A

INSERTION/EXTRACTION TOOL: N/A

MSSS, MALE, SBCM,
SURFACE MOUNT, STRAIGHT PIN

PART NO.

MSSS-5982

REVISION

F

SHEET 1 OF 1 OL5982 4-30-03 RF MP