

COMPONENT	MATERIAL AND FINISH	
SHROUD, BUSHING	303 CRES, ASTM A582	PASSIVATE, AMS-QQ-P-35
CONTACT	BeCu, ASTM B196, UNS C17300	GOLD PLATE, MIL-G-45204 TYPE 1, GRADE C , CLASS 1
INSULATOR	PTFE, ASTM D1710 TYPE I , GRADE 1 , CLASS A	

PART NO. MMSP-3875

OUTLINE DRAWING

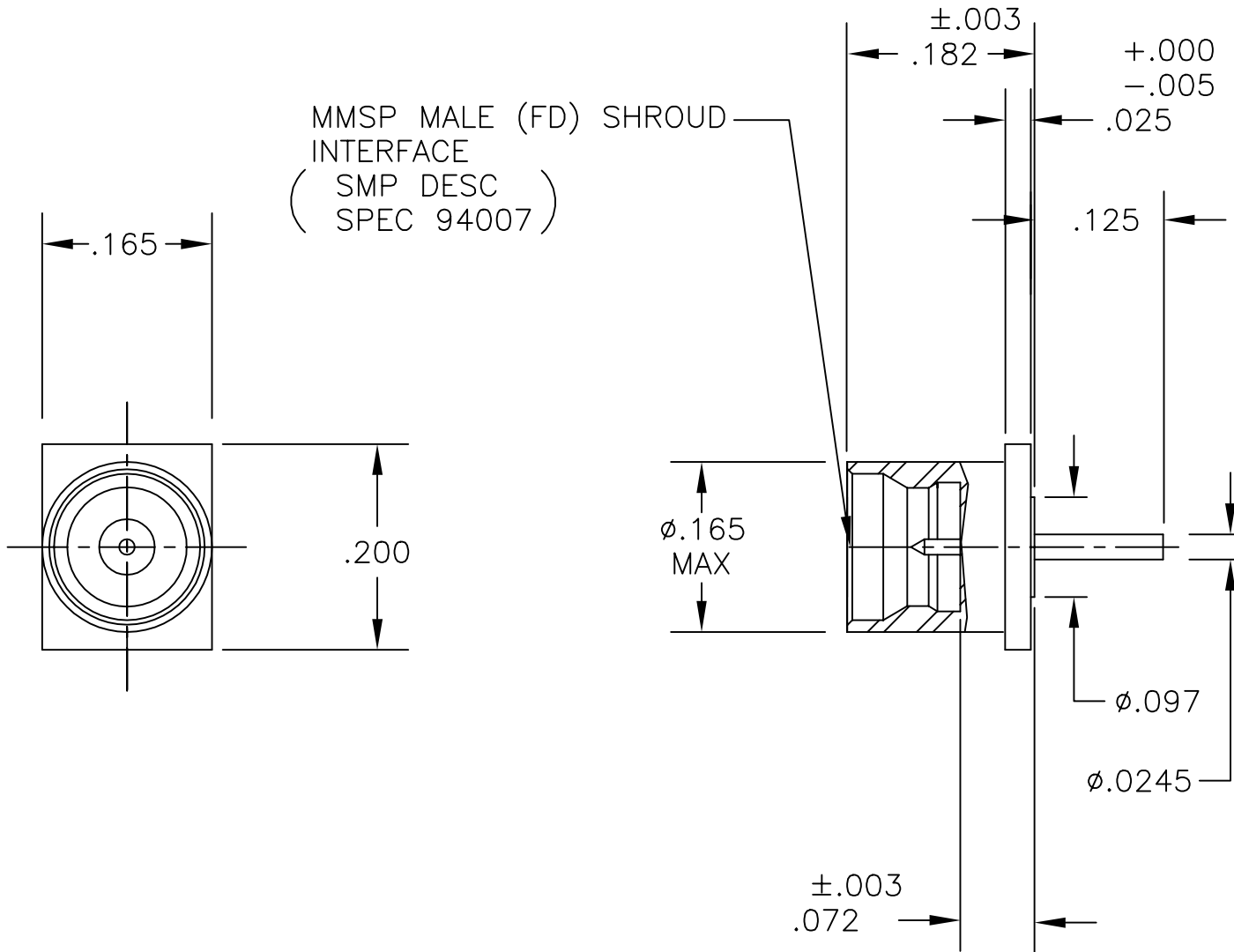

MICRO-MODE PRODUCTS, INC.
The Reliable Connection to the Future

El Cajon, CA 92020
(619) 449-3844

CAGE CODE
15907

ASSY PROCEDURES:		MMSP, MALE, FD, .025 FLG SHROUD, STRAIGHT TERMINAL	
INSERTION/EXTRACTION TOOL:			
SHEET 1 OF 1		PART NO.	REVISION
OL3875	10-3-00	RF DR	MMSP-3875 A