

COMPONENT	MATERIAL AND FINISH	
BODY, BUSHING	303 CRES, ASTM A582	GOLD PLATE, MIL-G-45204, TYPE 1, GRADE C, CLASS 2
INSULATORS	PTFE, ASTM D1710, TYPE I, GRADE 1, CLASS A	
CONTACT	BeCu, ASTM B196, UNS C17300	GOLD PLATE, MIL-G-45204, TYPE 1, GRADE C, CLASS 1
PIN	KOVAR PER MIL-I-23011, ASTM F15	GOLD PLATE, MIL-G-45204, TYPE 1, GRADE C, CLASS 1
GLASS PREFORM	CORNING #7052 OR EQUIVALENT	

PART NO. MTNC-3380

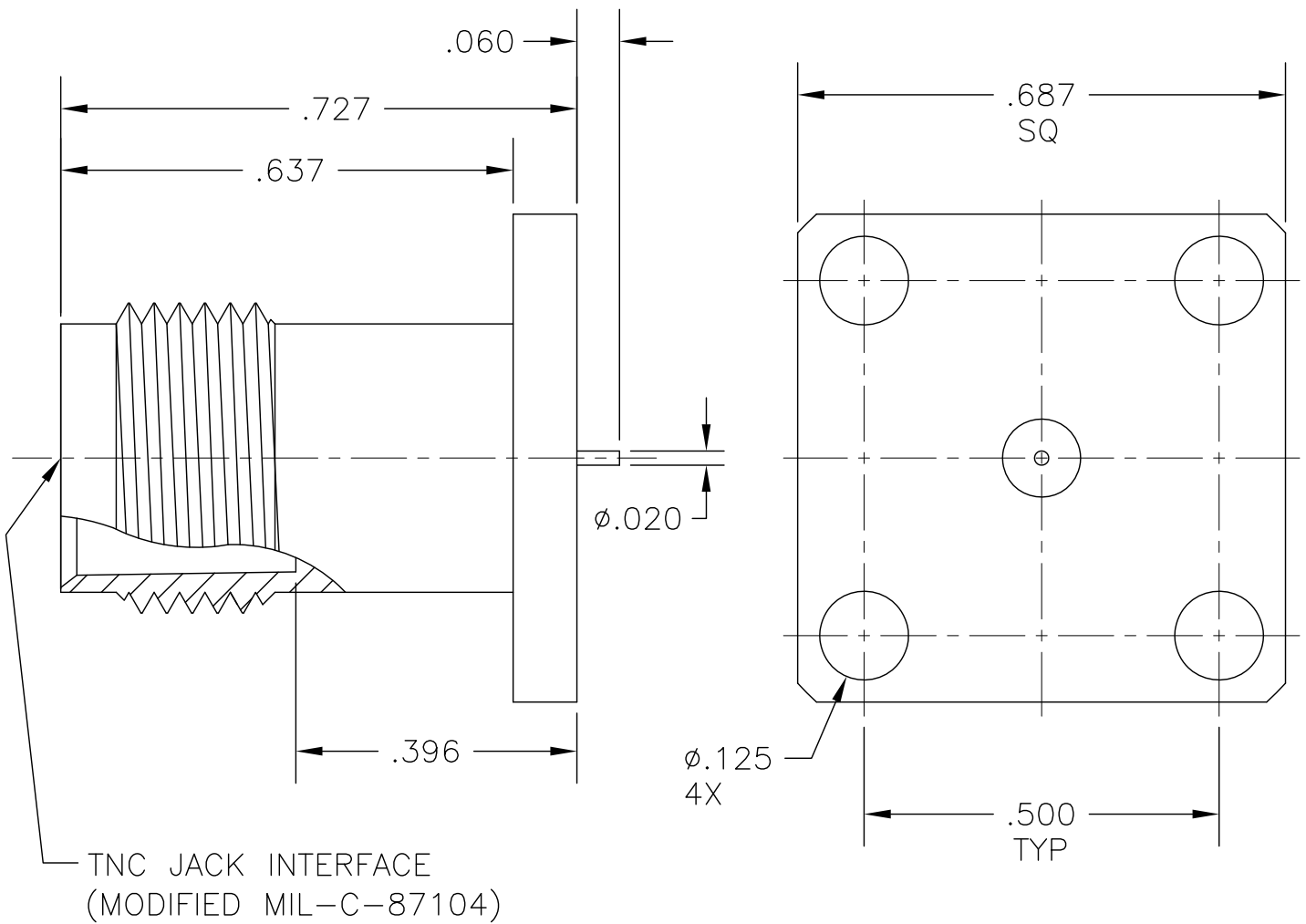

OUTLINE DRAWING



MICRO-MODE PRODUCTS, INC.
The Reliable Connection to the Future

El Cajon, CA 92020
ph 619.449.3844
www.micromode.com

CAGE CODE
15907

ASSY PROCEDURES: N/A

TOOL: N/A

TNC JACK, HERMETIC,
.687 SQ FLANGE

SHEET 1 OF 1 | OL3380 7-12-99 | JH PC

PART NO.

MTNC-3380

REVISION

D