

COMPONENT	MATERIAL AND FINISH	
BODY, LOCKWASHER	303 CRES, ASTM A582 PASSIVATE, AMS-QQ-P-35	GOLD PLATE, MIL-G-45204, TYPE 1, GRADE C, CLASS 1
INSULATORS	PTFE, ASTM D1710, TYPE I, GRADE 1, CLASS A	
CONTACTS	BeCu, ASTM B196, UNS C17300	GOLD PLATE, MIL-G-45204, TYPE 1, GRADE C, CLASS 1
JAM NUT	BRASS, ASTM B16, UNS C36000	GOLD PLATE, MIL-G-45204, TYPE 1, GRADE C, CLASS 1
O-RING	SILICONE, ASTM D1418	

PART NO. 2402-2-0890-000 HG 1

OUTLINE DRAWING

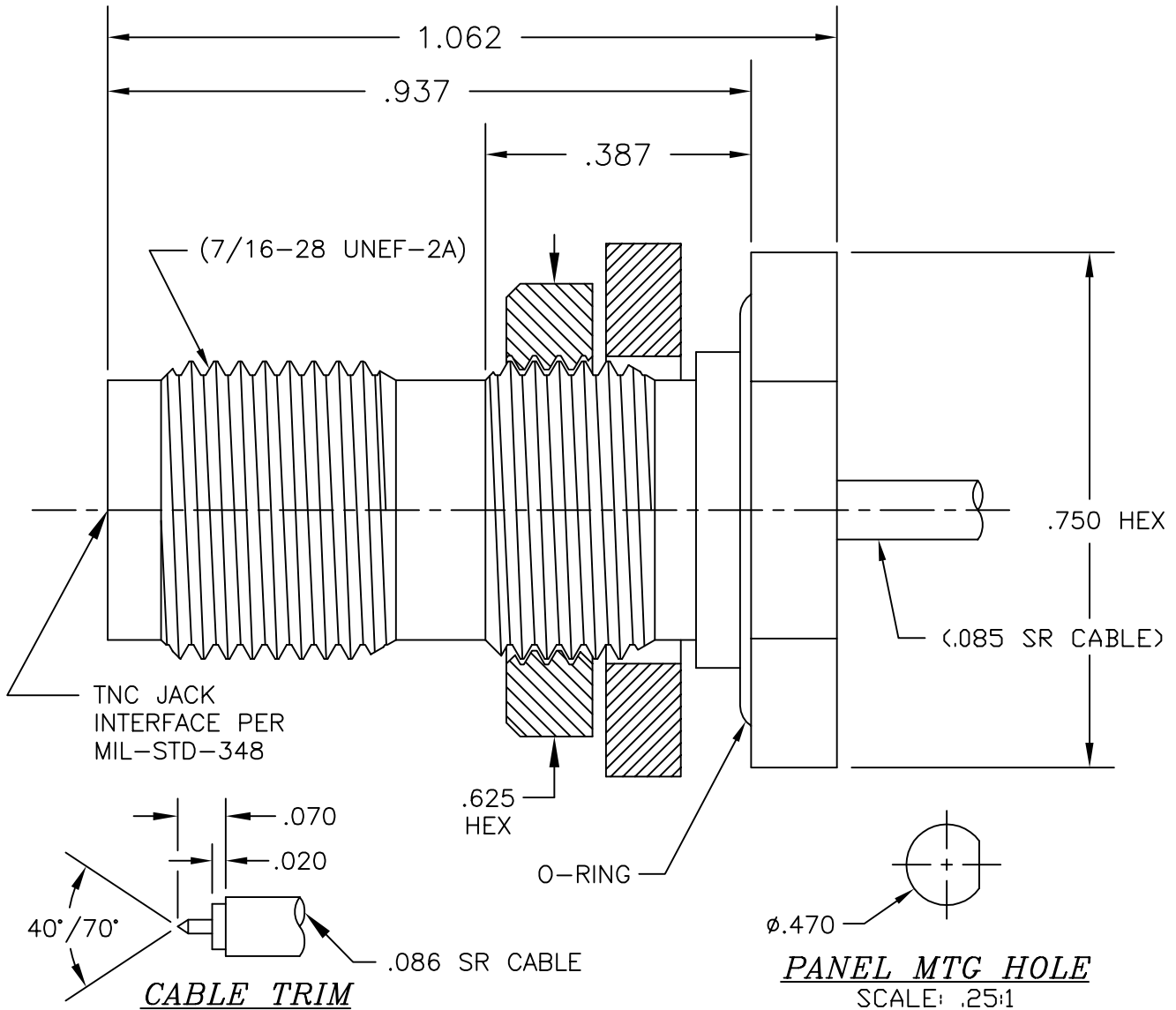

MICRO-MODE PRODUCTS, INC.
The Reliable Connection to the Future

El Cajon, CA 92020
ph 619.449.3844
www.micromode.com

CAGE CODE
15907

ASSY PROCEDURES: MMAP-5426

INSERTION/EXTRACTION TOOL: N/A

TNC JACK, BULKHEAD FEEDTHRU,
HERMETIC, .085 SR CABLE

SHEET 1 OF 1 | OL2402-2... 7-19-02 RF MP

PART NO.

2402-2-0890-000 HG

REVISION

01