

COMPONENT	MATERIAL AND FINISH	
BODY	304L CRES, ASTM A276	PASSIVATE, AMS-QQ-P-35
INSULATORS	PTFE, ASTM D1710, TYPE I, GRADE 1, CLASS A	
CONTACTS, SOLDER SLEEVE	BeCu, ASTM B196, UNS C17300	GOLD PLATE, MIL-G-45204, TYPE 1, GRADE C, CLASS 1
GLASS	CORNING #7052 OR EQUIVALENT	
PIN	KOVAR ASTM F35	GOLD PLATE, MIL-G-45204, TYPE 1, GRADE C, CLASS 1
O-RING	SILICONE, ASTM D1418	
JAM NUT, CLAMP NUT, BUSHING	303 CRES, ASTM A582	PASSIVATE, AMS-QQ-P-35
LOCKWASHER	410 CRES	PASSIVATE, AMS-QQ-P-35

PART NO. MTNC-5443

OUTLINE DRAWING

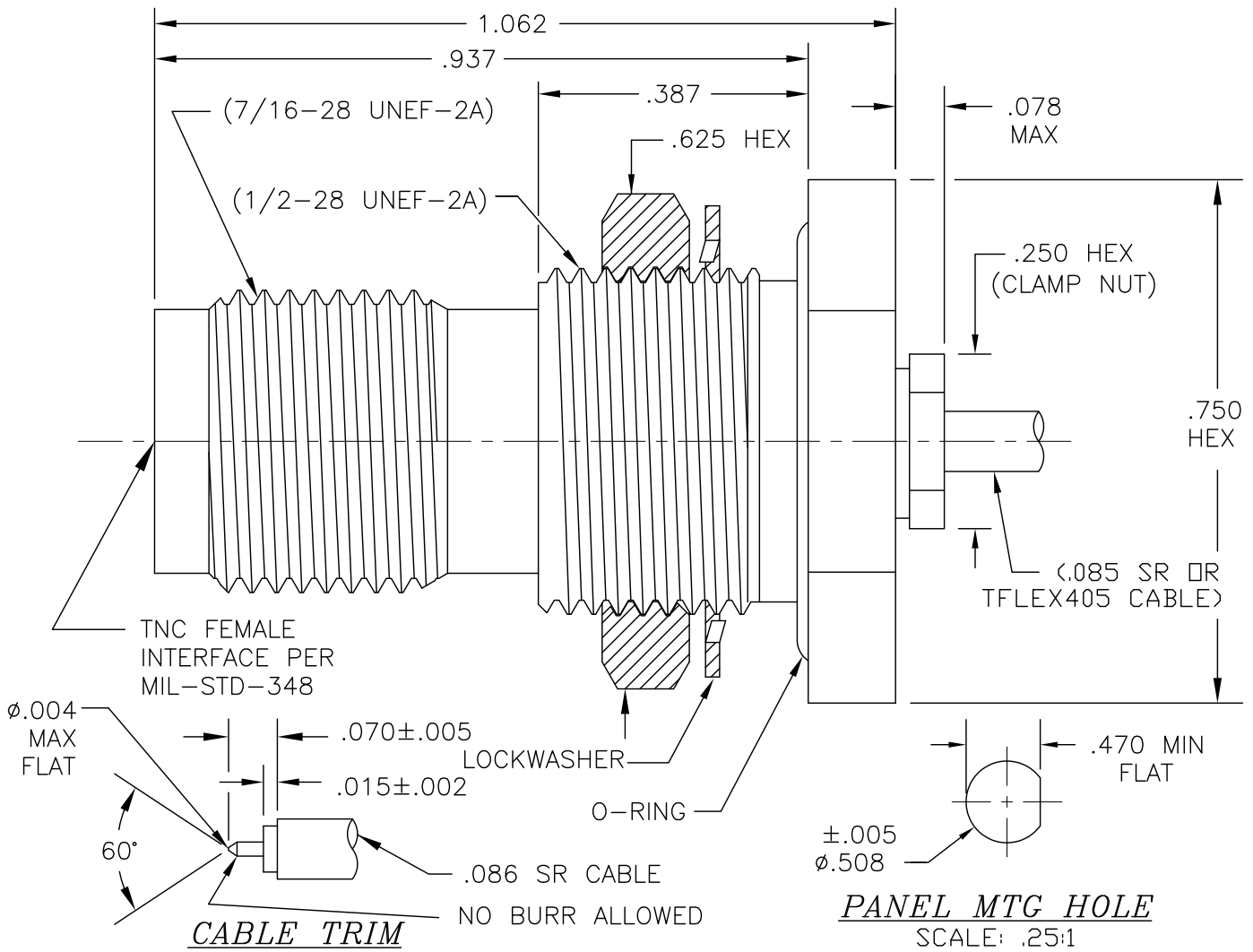

MICRO-MODE PRODUCTS, INC.  
*The Reliable Connection to the Future*

El Cajon, CA 92020  
 ph 619.449.3844  
 www.micromode.com

CAGE CODE  
 15907

ASSY PROCEDURES: MMAP-5426

INSERTION/EXTRACTION TOOL: N/A

TNC FEMALE, BULKHEAD FEEDTHRU,  
 HERMETIC, .085 SR OR TFLEX405

PART NO.

REVISION

SHEET 1 OF 1 OL5443 3-13-03 MT EB

MTNC-5443

E