

COMPONENT	MATERIAL AND FINISH	
BODY	304L PER ASTM A276	
PIN	KOVAR PER MIL-I-23011 ASTM F15	GOLD PLATE, MIL-G-45204, TYPE 1, GRADE C, CLASS 1
GLASS	CORNING #7070 OR EQUIVALENT	

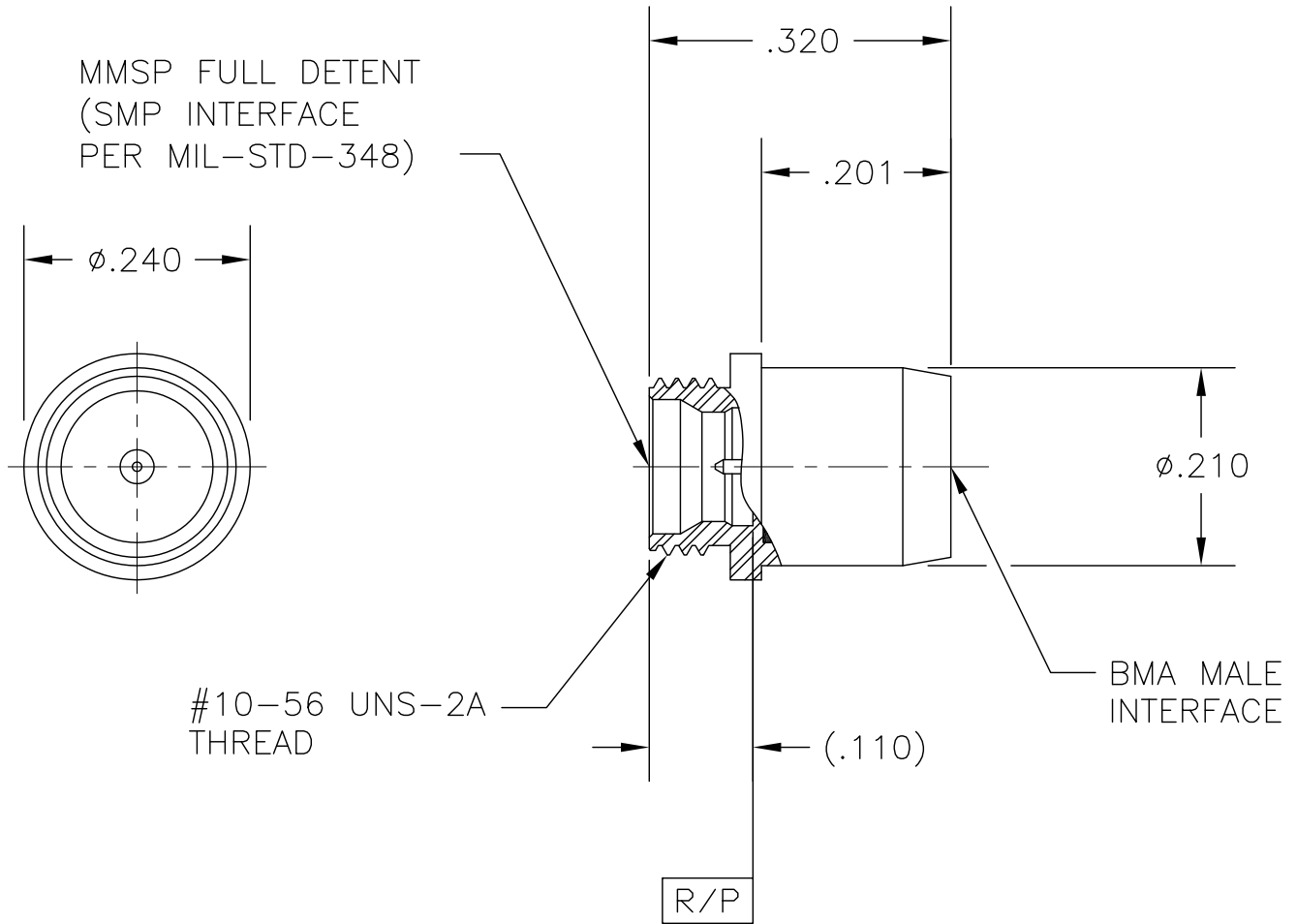

PART NO. MADP-3262

OUTLINE DRAWING



MICRO-MODE PRODUCTS, INC.
The Reliable Connection to the Future

El Cajon, CA 92020
ph 619.449.3844
www.micromode.com

CAGE CODE
15907

ASSY PROCEDURES: N/A

INSERTION/EXTRACTION TOOL: N/A

MMSF MALE FULL DETENT
TO BMA PIN CONTACT, THREAD-IN ADAPTER

PART NO.

MADP-3262

REVISION

D

SHEET 1 OF 1 OL3262 4-27-99 JJC EB