

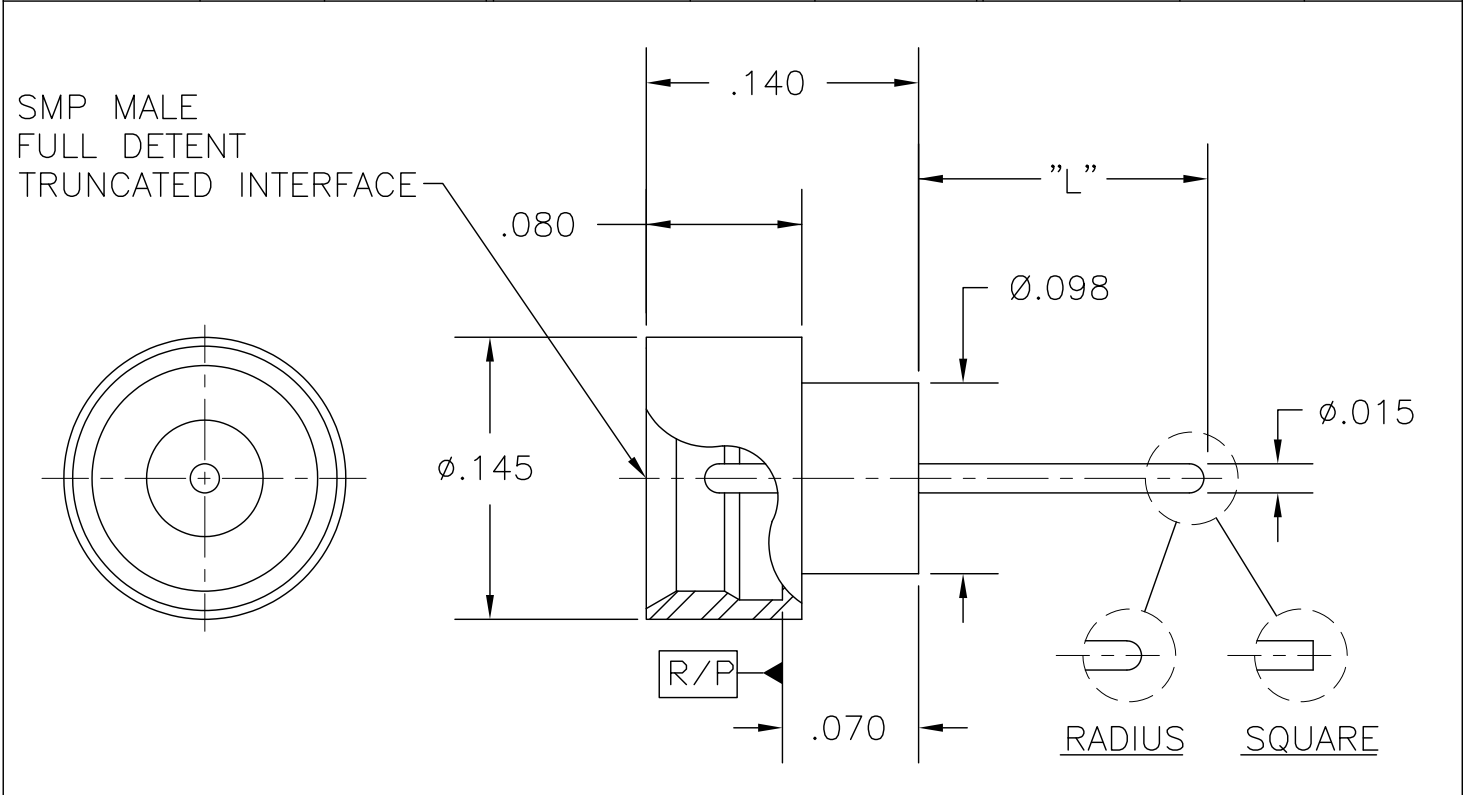

COMPONENT			MATERIAL AND FINISH					
BODY & PIN			KOVAR PER MIL-I-23011 ASTM F-15			GOLD PLATE, MIL-G-45204, TYPE 1, GRADE C, CLASS 1		
GLASS			CORNING #7070 OR EQUIVALENT					
PART NUMBER	LENGTH "L"	PIN END	PART NUMBER	LENGTH "L"	PIN END	PART NUMBER	LENGTH "L"	PIN END
MMSP-2701	.025	RADIUS	MMSP-2719	.070	RADIUS	MMSP-2737	.115	RADIUS
MMSP-2702	.025	SQUARE	MMSP-2720	.070	SQUARE	MMSP-2738	.115	SQUARE
MMSP-2703	.030	RADIUS	MMSP-2721	.075	RADIUS	MMSP-2739	.120	RADIUS
MMSP-2704	.030	SQUARE	MMSP-2722	.075	SQUARE	MMSP-2740	.120	SQUARE
MMSP-2705	.035	RADIUS	MMSP-2723	.080	RADIUS	MMSP-2741	.125	RADIUS
MMSP-2706	.035	SQUARE	MMSP-2724	.080	SQUARE	MMSP-2742	.125	SQUARE
MMSP-2707	.040	RADIUS	MMSP-2725	.085	RADIUS	MMSP-2743	.130	RADIUS
MMSP-2708	.040	SQUARE	MMSP-2726	.085	SQUARE	MMSP-2744	.130	SQUARE
MMSP-2709	.045	RADIUS	MMSP-2727	.090	RADIUS	MMSP-2745	.135	RADIUS
MMSP-2710	.045	SQUARE	MMSP-2728	.090	SQUARE	MMSP-2746	.135	SQUARE
MMSP-2711	.050	RADIUS	MMSP-2729	.095	RADIUS	MMSP-2747	.140	RADIUS
MMSP-2712	.050	SQUARE	MMSP-2730	.095	SQUARE	MMSP-2748	.140	SQUARE
MMSP-2713	.055	RADIUS	MMSP-2731	.100	RADIUS	MMSP-2749	.145	RADIUS
MMSP-2714	.055	SQUARE	MMSP-2732	.100	SQUARE	MMSP-2750	.145	SQUARE
MMSP-2715	.060	RADIUS	MMSP-2733	.105	RADIUS	MMSP-2751	.150	RADIUS
MMSP-2716	.060	SQUARE	MMSP-2734	.105	SQUARE	MMSP-2752	.150	SQUARE
MMSP-2717	.065	RADIUS	MMSP-2735	.110	RADIUS			
MMSP-2718	.065	SQUARE	MMSP-2736	.110	SQUARE			

PART NO. MMSP-2701 → MMSP-2752



OUTLINE DRAWING

 MICRO-MODE PRODUCTS, INC. <i>The Reliable Connection to the Future</i>		El Cajon, CA 92020 ph 619.449.3844 www.micromode.com	CAGE CODE 15907
ASSY PROCEDURE: MMAP-2695 LOCATOR TOOL: MMTL-2696		MMSP, MALE, FULL DETENT HERMETIC SHROUD	
SHEET 1 OF 1 OL2701 4-27-98 MM EB		PART NO. MMSP-2701 → MMSP-2752	REVISION D